

### Digital Laser Sensor Amplifier LS-400 Series

Thank you very much for purchasing Panasonic products. Please read this Instruction Manual carefully and thoroughly for the correct and optimum use of this product. Kindly keep this manual in a convenient place for quick reference.

#### ⚠ WARNING

- Never use this product as a sensing device for personnel protection.
- In case of using sensing devices for personnel protection, use products which meet laws or standards, such as OSHA, ANSI or IEC etc., for personnel protection applicable in each region or country.
- Use of control or adjustment or performance of procedures other than those specified in this instruction manual may result in hazardous radiation expose.

For details of the setting contents or setting procedure, refer to 'LS series PRO mode operation guide' in 'Panasonic Industrial Devices SUNX website (<http://panasonic.net/id/pidsx/global>)'.

## 1 PART DESCRIPTION

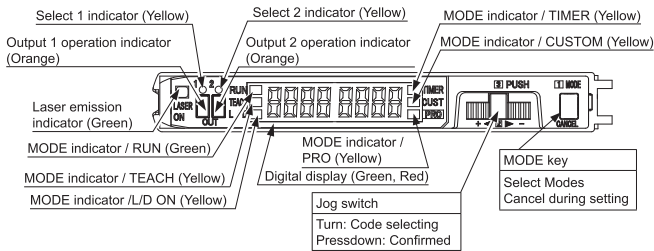

## 2 MOUNTING

### How to mount the amplifier

1. Fit the rear part of the mounting section of the amplifier on a DIN rail.
2. Press down the rear part of the mounting section of the unit on the DIN rail and fit the front part of the mounting section to the DIN rail.

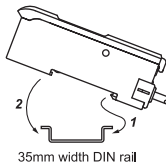

### How to remove the amplifier

1. Push the amplifier forward. (Note)
2. Lift up the front part of the amplifier to remove it.

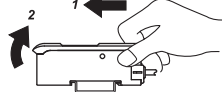

Note: Take care that if the front part is lifted without pushing the amplifier forward, the hook on the rear portion of the mounting section is likely to break.

### How to mount the sensor head

1. Insert the sensor head connector into the inlet until it clicks.
2. Fit the cover to the connector.

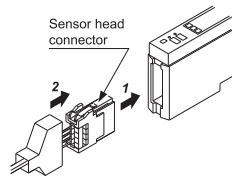

## 3 CASCADING CONNECTOR TYPE LS-401(P)

- For mounting and removing the amplifier, refer to '2 MOUNTING'.
- Up to maximum 15 amplifiers can be added. (total 16 amplifiers connected in cascade.)
- When this product is used with the digital fiber amplifier, be sure to place this product to the left most position. (When viewed from the connector side) In case this product is not placed to the leftmost position, this product may not operate properly.

### Cascading method

1. Mount the amplifiers, one by one, on the 35mm width DIN rail.
2. Slide the amplifiers next to each other, and connect the quick-connection cables.
3. Mount the optional end plates (MS-DIN-E) at both the ends to hold the amplifiers between their flat sides.
4. Tighten the screws to fix the end plates.

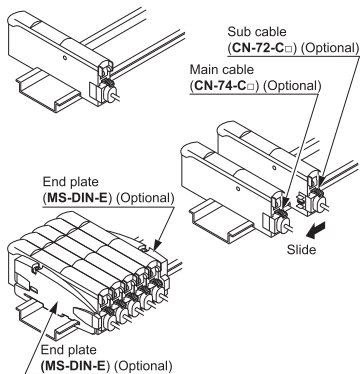

### Dismantling method

1. Loosen the screws of the end plates.
2. Remove the end plates.
3. Slide the amplifiers and remove them one by one.

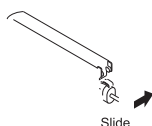

## 4 I/O CIRCUIT DIAGRAM

### • NPN output type

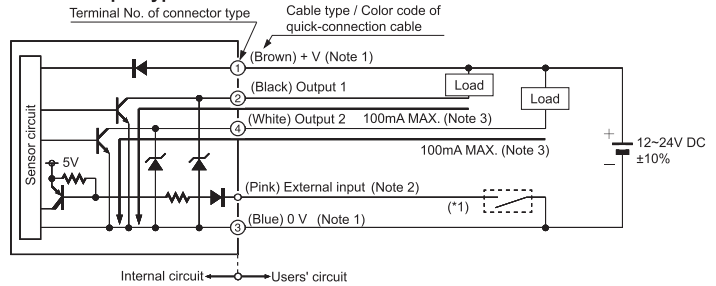

### • PNP output type

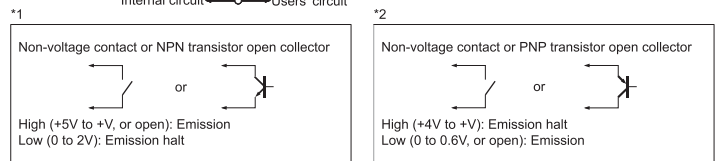
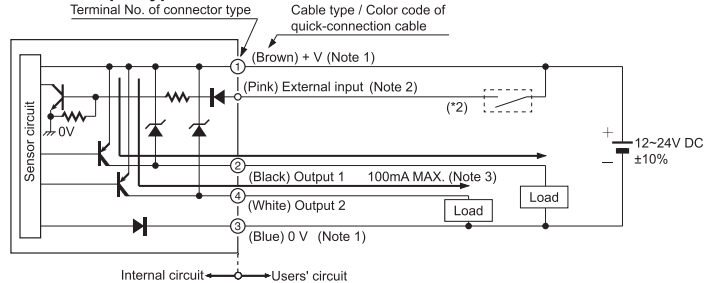

- Notes :1) The quick-connection sub cable does not have +V (brown) and 0V (blue). The power is supplied from the connector of the main cable.  
2) External input is not incorporated with the connector type LS-401(P).  
3) 50mA max. if 5 to 8 units are connected in cascade, and 25mA max. if 9 to 16 units are connected in cascade.

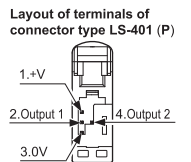

## 5 EXTERNAL INPUT [only for LS-401(P)-C2]

- When 'emission halt', 'limit teaching' or 'full-auto teaching' is set, the time chart is as follows.

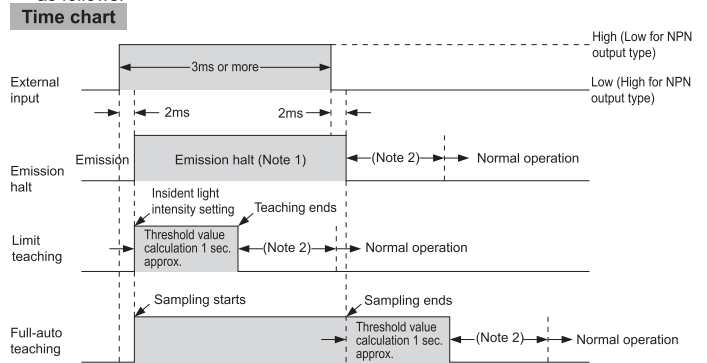

- Notes :1) In the emission halt state, since the incident light intensity is judged as 0, the signal is output when the emission halt is confirmed (the trailing differential mode is selected) or the emission halt is canceled (the rising differential mode is selected) in the differential mode.  
2) The output operation only for response time is not fixed.

## 6 OPERATION PROCEDURE

- Be sure to set each item after selecting the output 1 or the output 2.
- The items that can be set in the output 1 and the output 2 respectively are only 1. Threshold value, 2. Output operation, 3. Timer operation and Timer period, and 4. Detection mode. The items other than those are common. (However, in case of setting with the direct code, a combination of the output 1/2 can be set only for output operation. The items other than output operation are valid only for the output 1.)
- System of basic operation  
The amplifier of LS-400 series features and settings are generally classified into two main modes; the 'NAVI' mode for items and settings that are frequently re-configured, and the 'PRO' mode that contains more detailed settings.

### Procedures for switching the NAVI mode

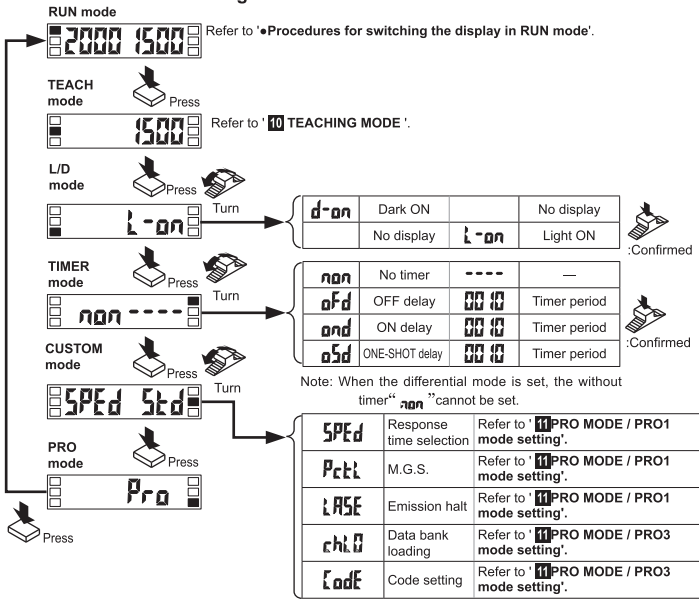

### Procedures for switching the display in RUN mode

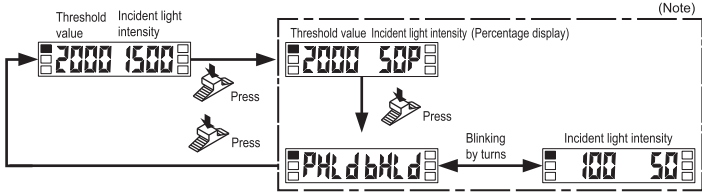

\*Displayed only in Window comparator mode or Hysteresis mode and Differential mode.

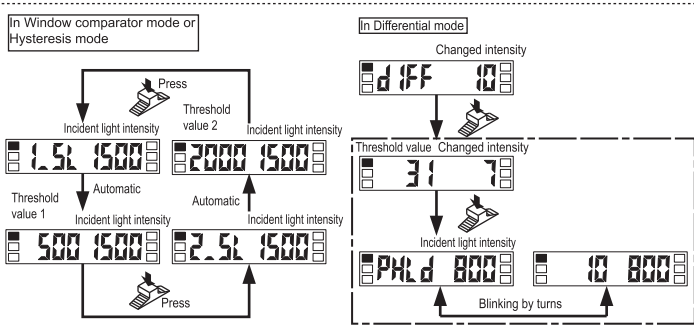

Note: \* Can be displayed if the display switching "d-t.c" is set to "oFF" to enable the display switching in PRO2 of PRO mode.

## 7 THRESHOLD VALUE FINE ADJUSTMENT FUNCTION

- The threshold can be fine-adjusted when the MODE indicator / RUN (green) lights up.
- Turn the jog switch to either '+' (left) or '-' (right) to increase / decrease the threshold value.
- The value is automatically memorized unless TEACH mode is selected after the adjustment or any switch operation is not carried out within a certain period of time.

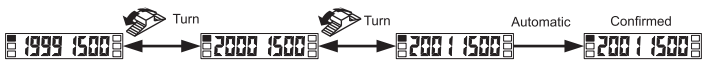

※: When you turn the jog switch to '+' or '-' in Window comparator mode or Hysteresis mode, the threshold will increase or decrease after the output 1 "1.5L" or the output 2 "2.5L" is displayed.

If you turn the jog switch to '+' when the output 1 "1.5L" is displayed, the following will be displayed.

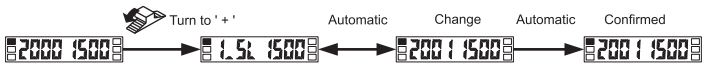

## 8 OUTPUT CHANNEL SWITCHING

- Press the MODE key for more than 2 seconds when in NAVI mode. If Output 1 has been selected, the Select 1 indicator (yellow) lights up. If the output 2 is being selected, the Select 2 indicator (yellow) lights up.

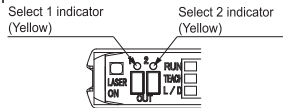

## 9 KEYLOCK FUNCTION

- If the jog switch and MODE key are pressed down simultaneously for more than 3 seconds when the MODE indicator / RUN (green) is on, the key operation is locked. Press down for more than 3 seconds again to unlock the key.



## 10 TEACHING MODE

When teaching in Window comparator mode or Hysteresis mode, a setting has to be made in PRO6 beforehand. In case of 1-level teaching, a shift value (the initial value is 100 digit or 15%) has to be set as well. teaching.

### In case of 2-level teaching

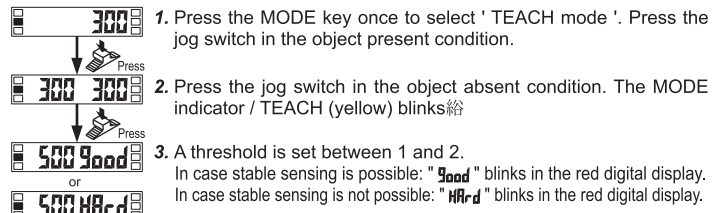

### In case of Limit-teaching

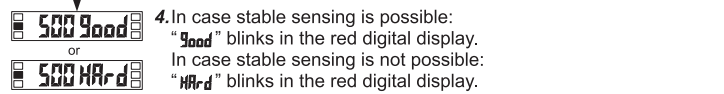
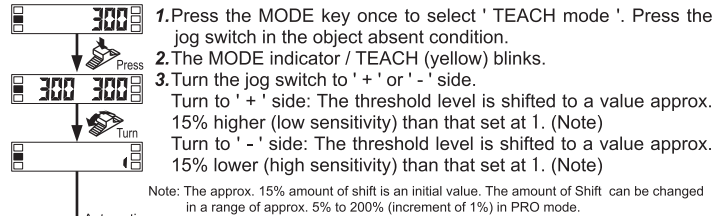

### In case of Full-auto teaching

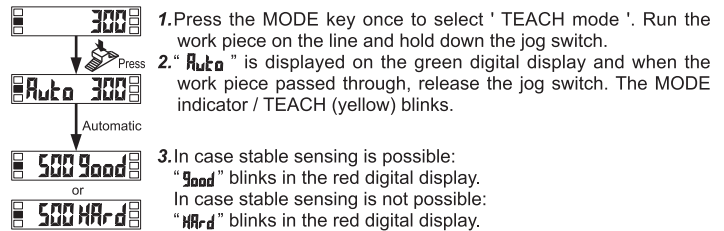

### In case of 1-level teaching in Window comparator mode or Hysteresis mode

- This is the method to set the shift value to the desired value and set the threshold range by using the single-point teaching.

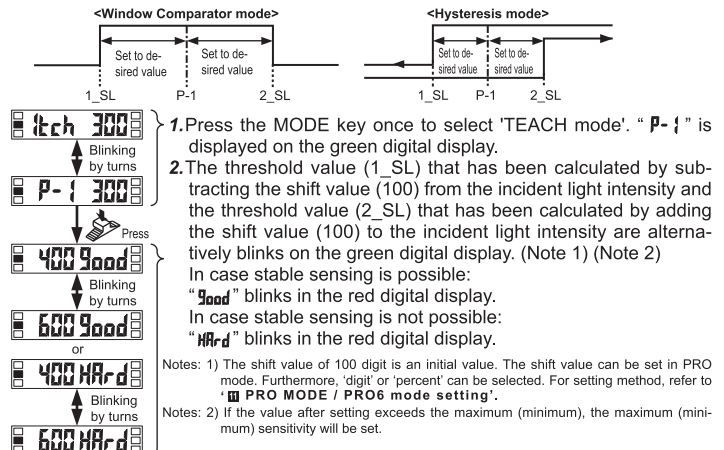

### In case of 2-level teaching in Window Comparator mode or Hysteresis mode

- This method is to set the threshold range by using the 2-point teaching (P-1, P-2).

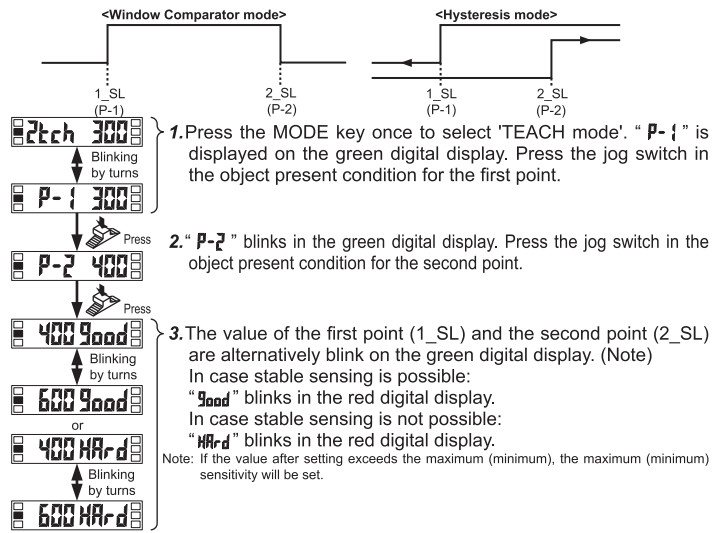

**In case of 3-level teaching in Window comparator mode or Hysteresis mode**

- This is the method to set the threshold range by setting the threshold (1\_SL) of the mid-point between 'A' and 'B' and the threshold (2\_SL) of the mid-point between 'B' and 'C', using the 3-point teaching (P-1, P-2, P-3).
- After teaching, P-1, P-2 and P-3 will be automatically relocated in ascending order: i.e. the lowest value is placed in 'A', the second lowest in 'B' and the highest in 'C'.

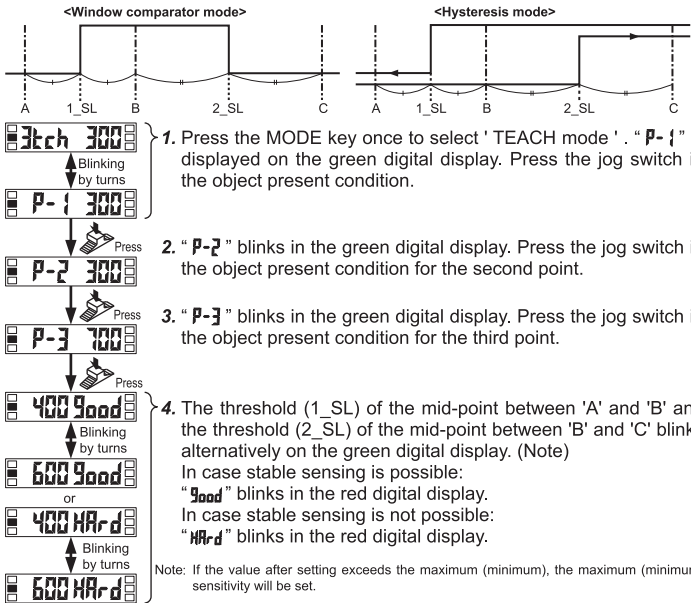

**Span adjustment in Differential mode**

- If Differential mode is selected when in PRO6 mode, ONE-SHOT timer (10ms) at the max. sensitivity is automatically set.
- Move to the rising differential mode, or the trailing differential mode in the PRO6 mode, and press the jog switch to confirm the setting.

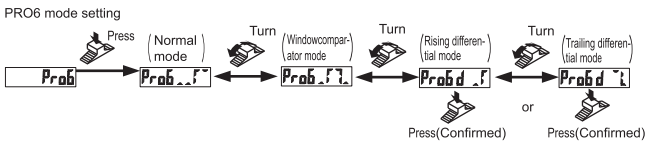

- The span adjustment in the differential mode can be set as follows in the TEACH mode. The value is automatically memorized unless L/D mode is selected after the adjustment or any switch operation is not carried out within a certain period of time.
- The threshold can be set by using the threshold value fine adjustment function. For details, refer to 'THRESHOLD VALUE FINE ADJUSTMENT FUNCTION'.

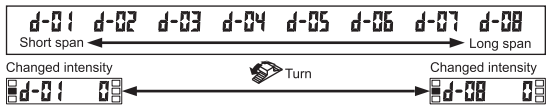

**PRO MODE**

- When MODE indicator / PRO (yellow) lights up, PRO mode can be set.



**PRO1 mode setting**

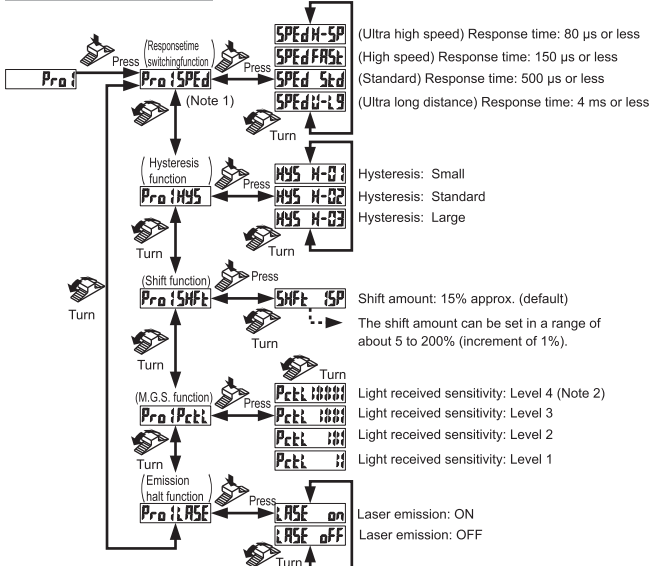

- Notes: 1) Display for laser amount can show the digit of max. 4,000 digits if 'H-SP' for ultra high speed or 'FAST' for high speed is selected in the response time switching function 'SPEED', but will display the digit of max. 9,999 digits if 'Std' for standard or 'U-L9' for ultra long distance is selected.
- 2) This can be selected only if 'SPEED' for ultra long distance (response time of 4ms or less) is selected in the response time switching function 'U-L9'.

**PRO2 mode setting**

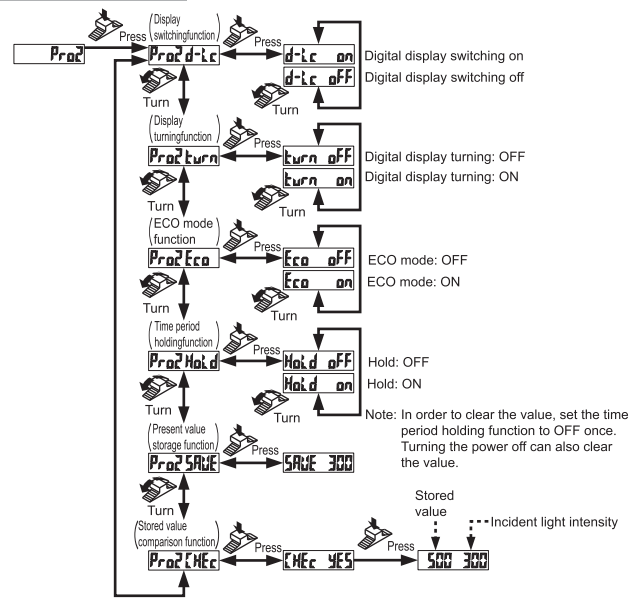

**PRO3 mode setting**

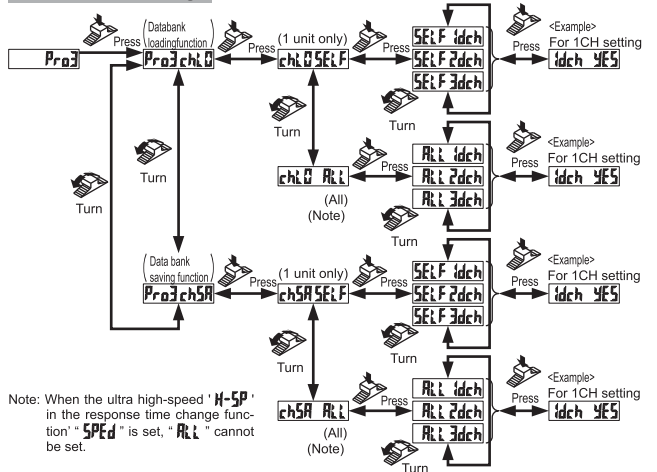

**PRO4 mode setting**

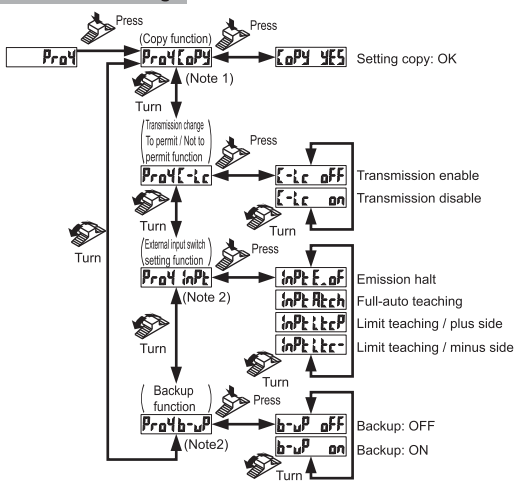

**PRO5 mode setting**

The 0-ADJ setting function in this product was removed from production starting May, 2005.

